

FU410-02-02

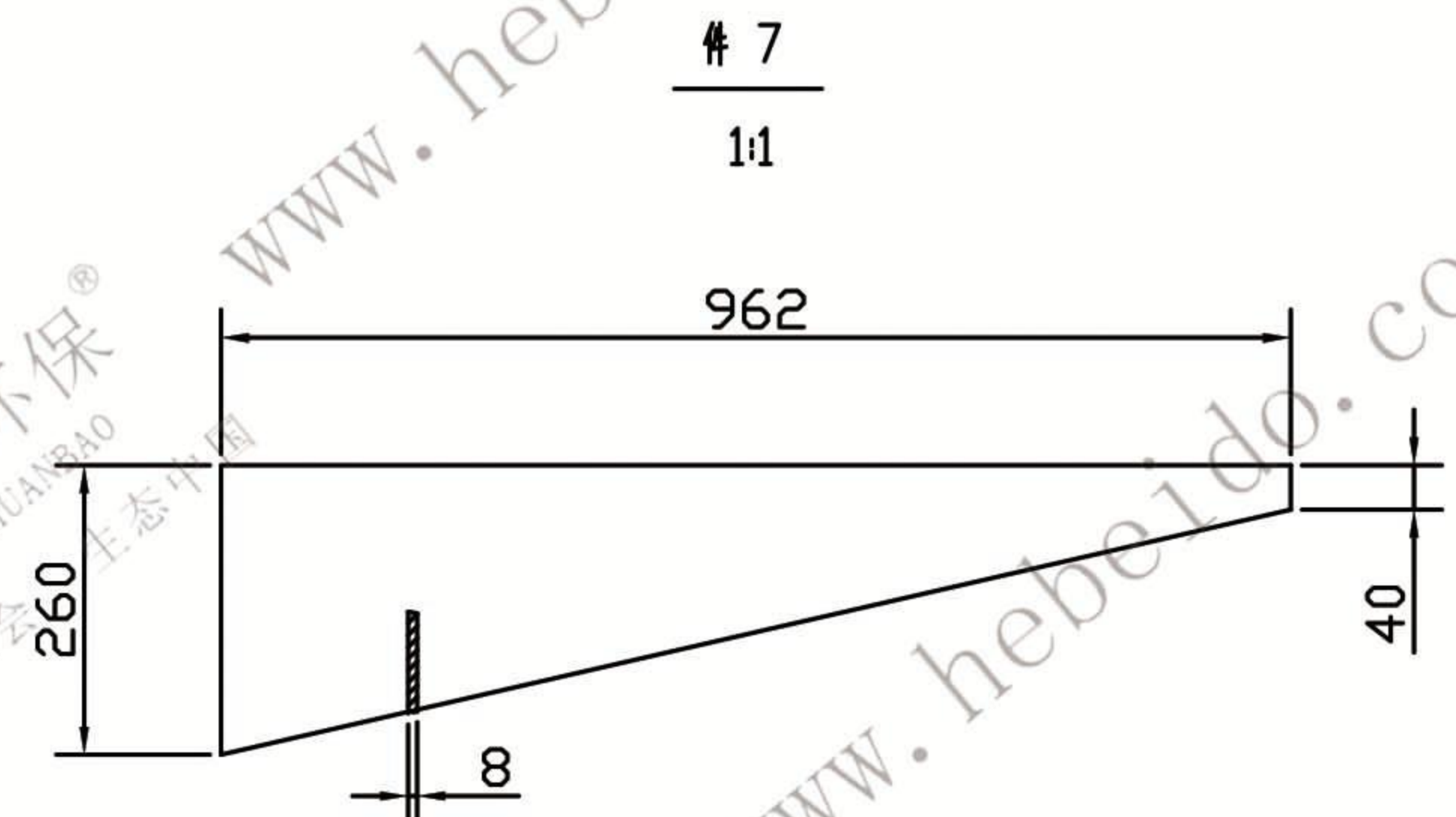

技术要求  
1. 件9在断FU410-02-02-4所要求尺寸前,按图尺寸焊

序号	代号	名称	数量	材料	单重	总重	备注
9	FU410-02-02-4	联接扁钢	1	Q235	1.78		
8	FU410-02-02-3	轴承座板	1	Q235	23.1		
7		撑板	1	Q235	9.06		
6		撑板	1	Q235	8.62		
5		加强筋	1	Q235	5.29		下料 562X150
4		角钢 40x40x4	1	Q235	2.32		下料 L=958
3		加强筋	2	Q235	0.31	0.62	
2	FU410-02-02-2	联接扁钢	1	Q235	2.40		
1	FU410-02-02-1	首节侧板	1	Q235	64.34		
							首节侧板复合
							FU410-02-02
							结构件
设计	校对	审核	制图	重量	比例		
李瑞	李瑞	李瑞	李瑞	118.59	1:10		
李瑞	李瑞	李瑞	李瑞				
李瑞	李瑞	李瑞	李瑞				

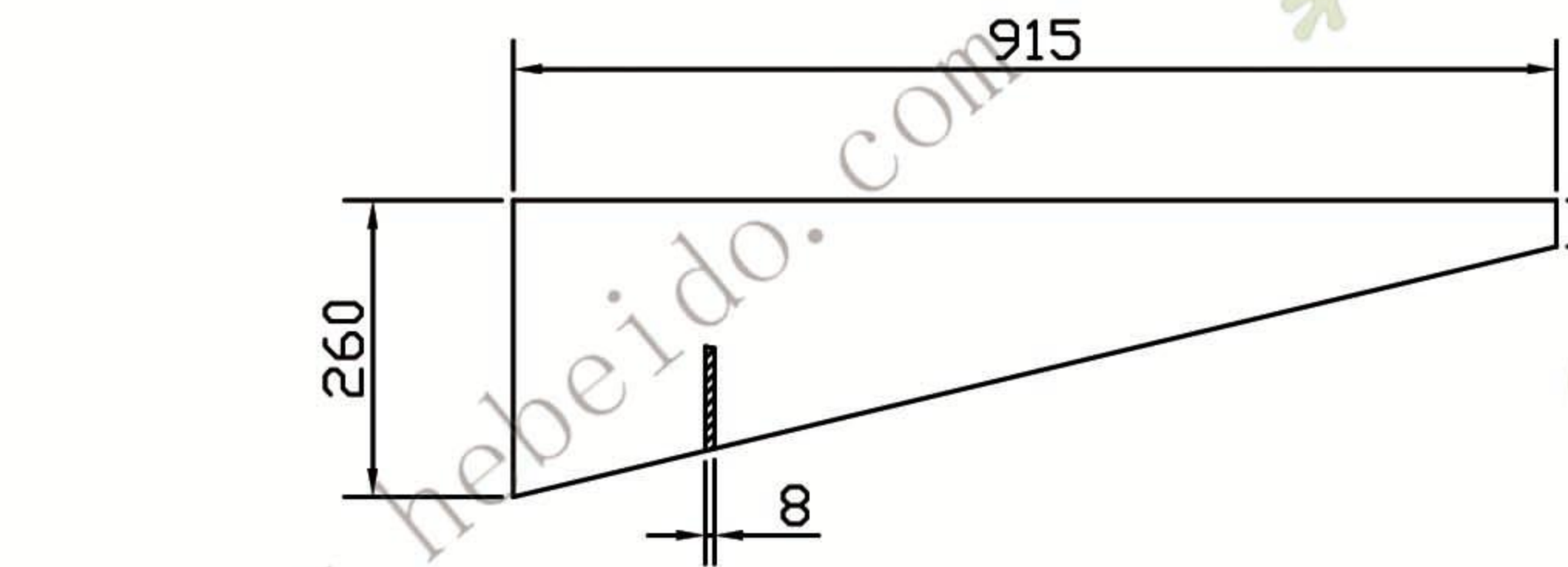
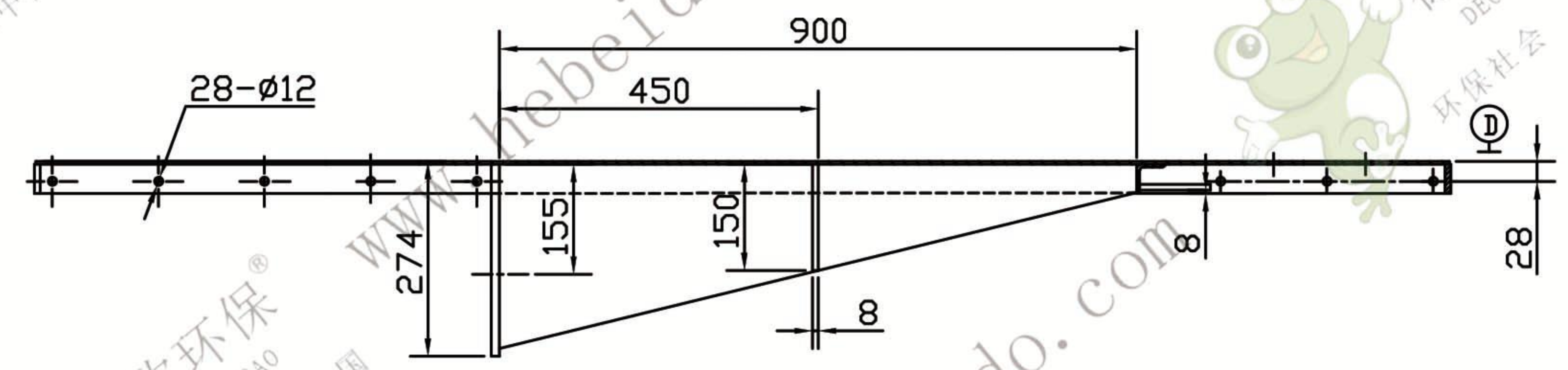
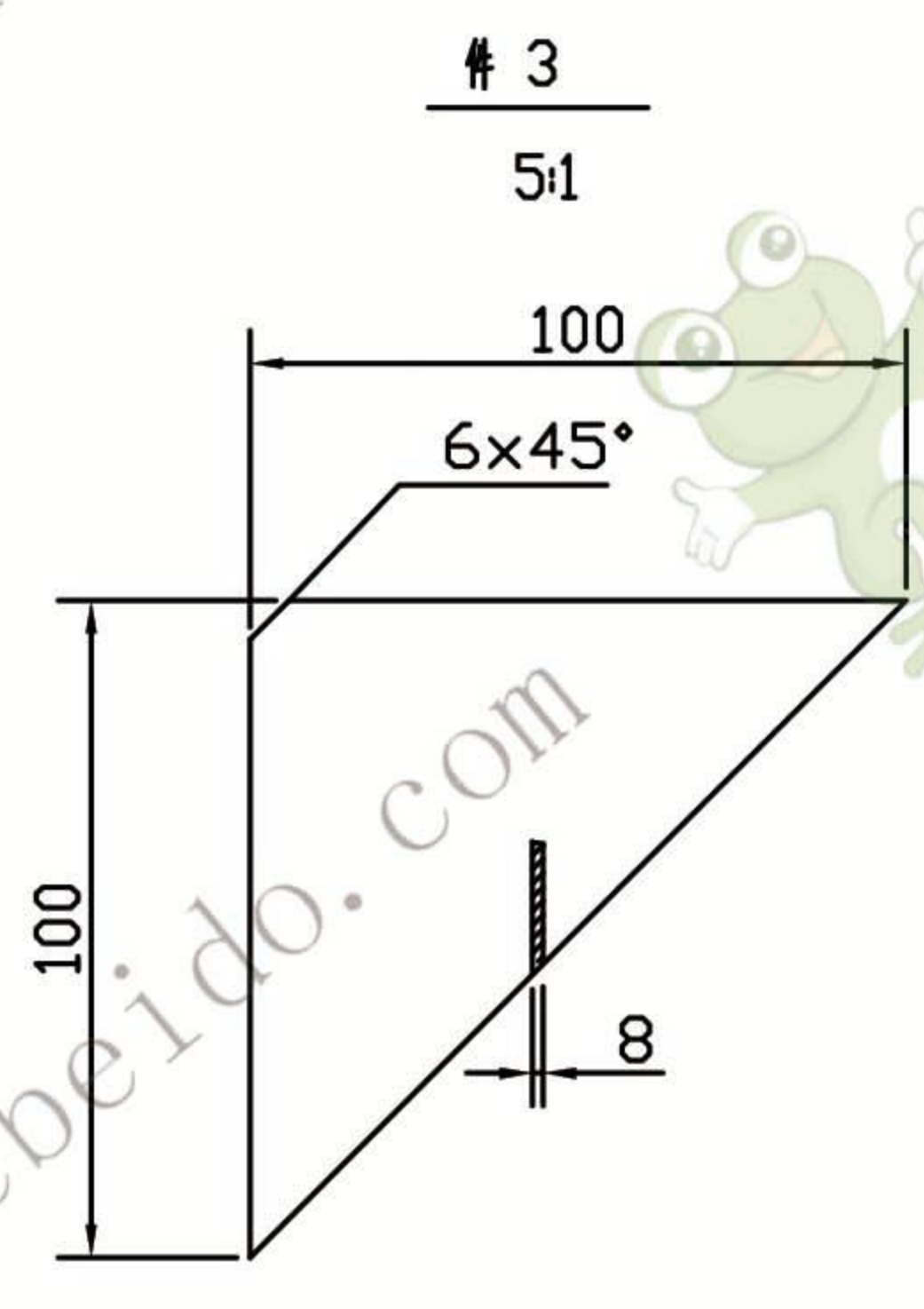
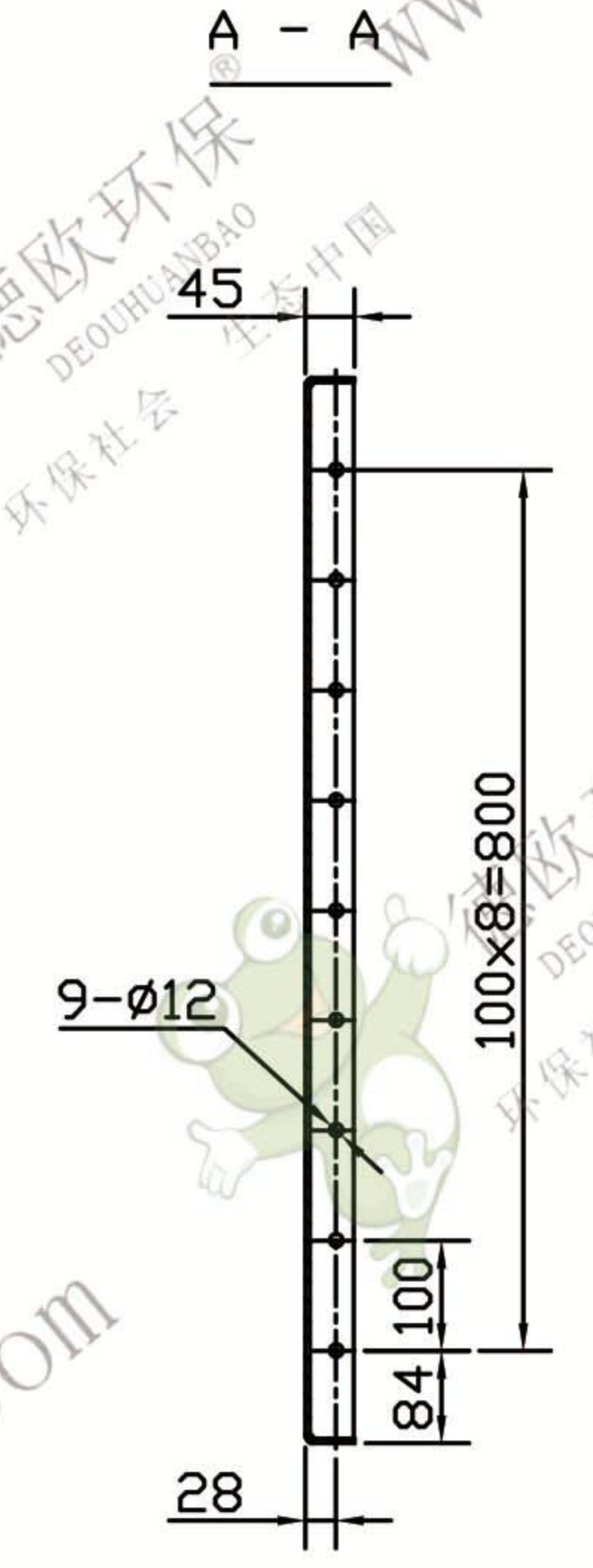
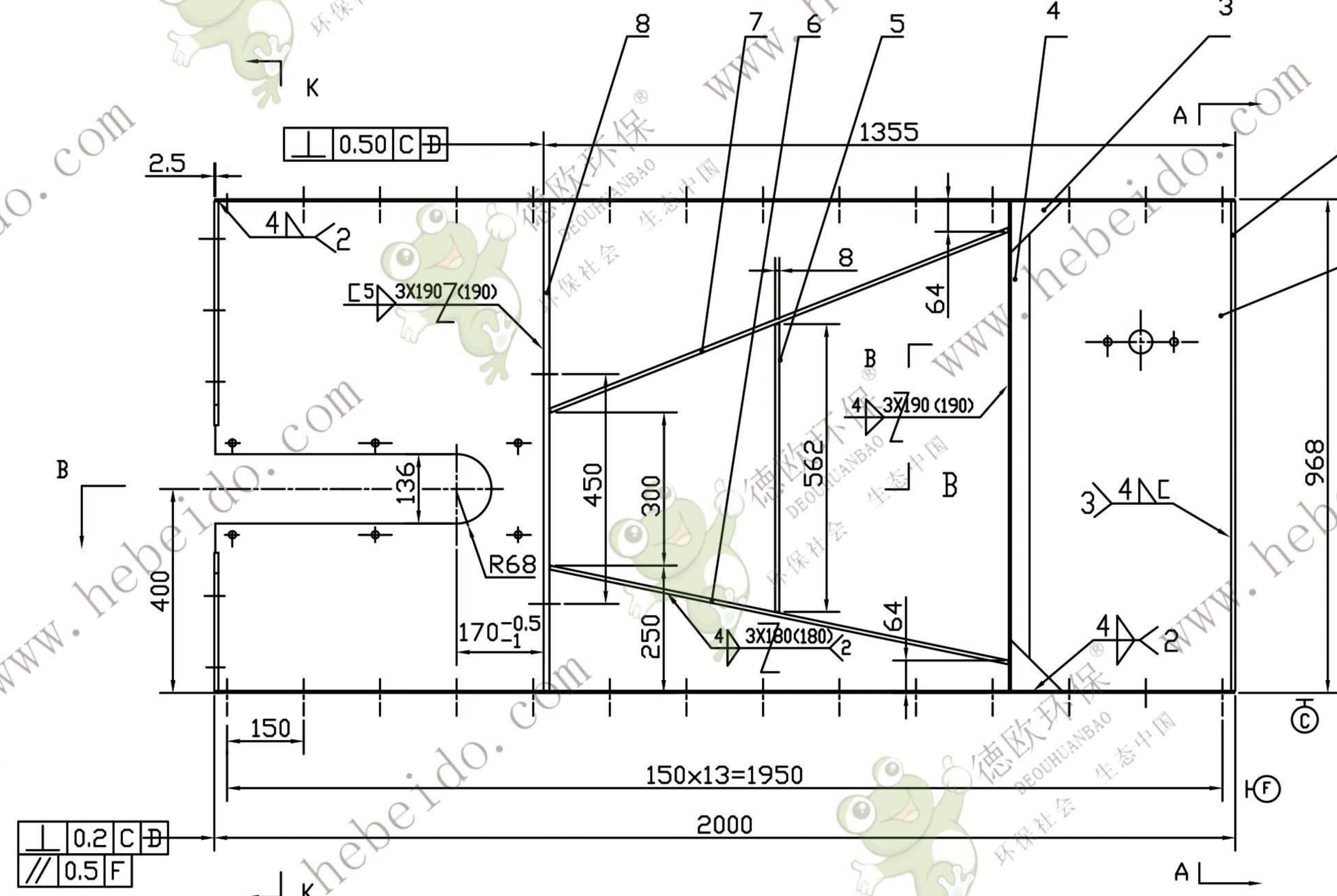
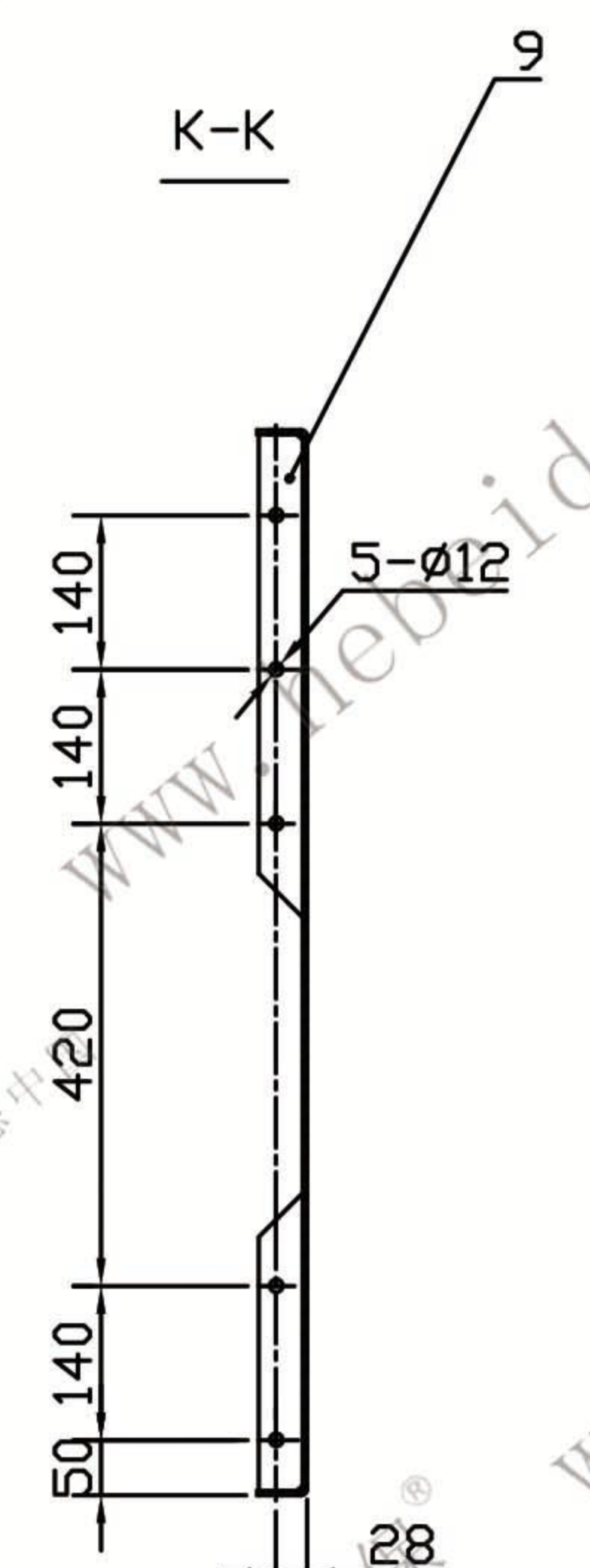