

标记	文件号	修改内容	签名	日期

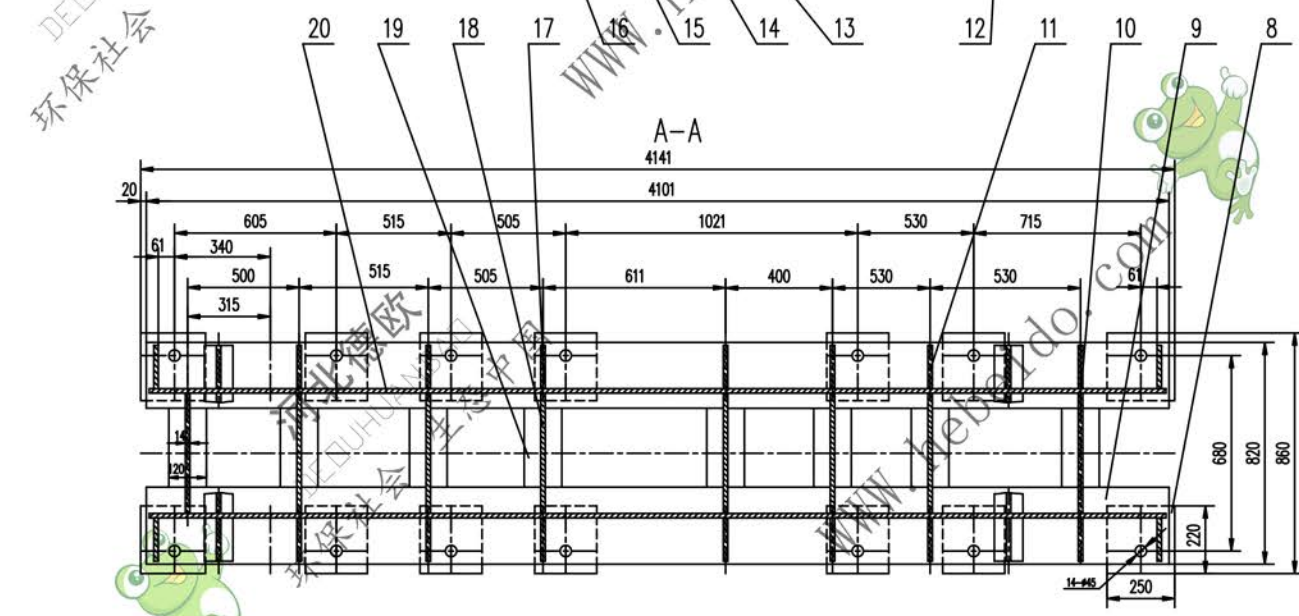
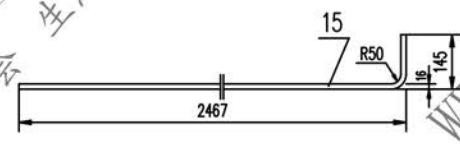
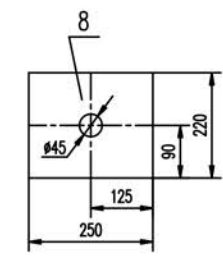
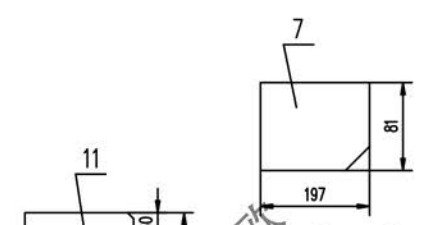
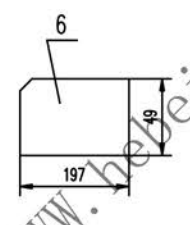
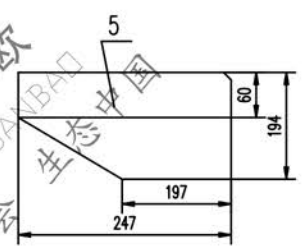
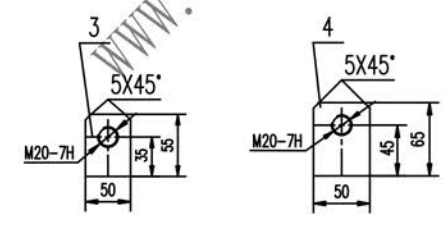
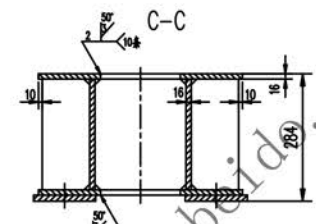
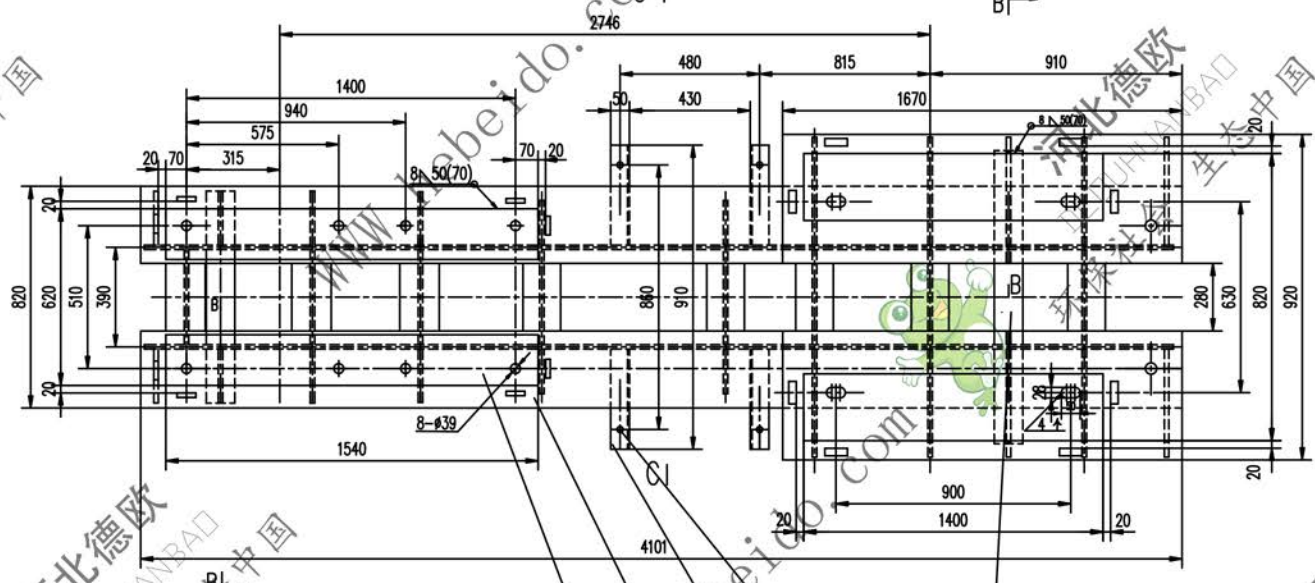
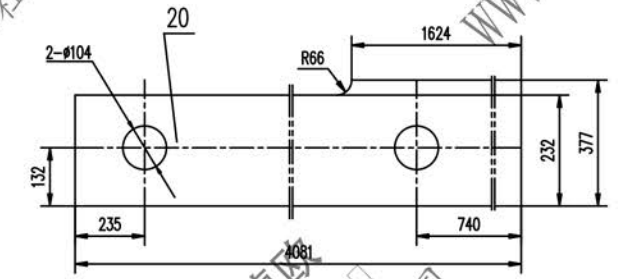
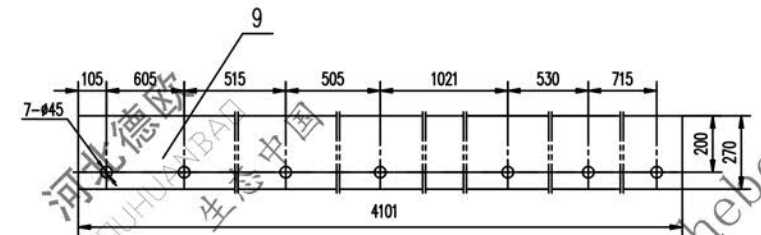
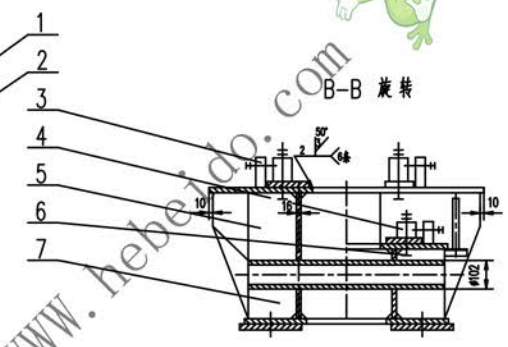
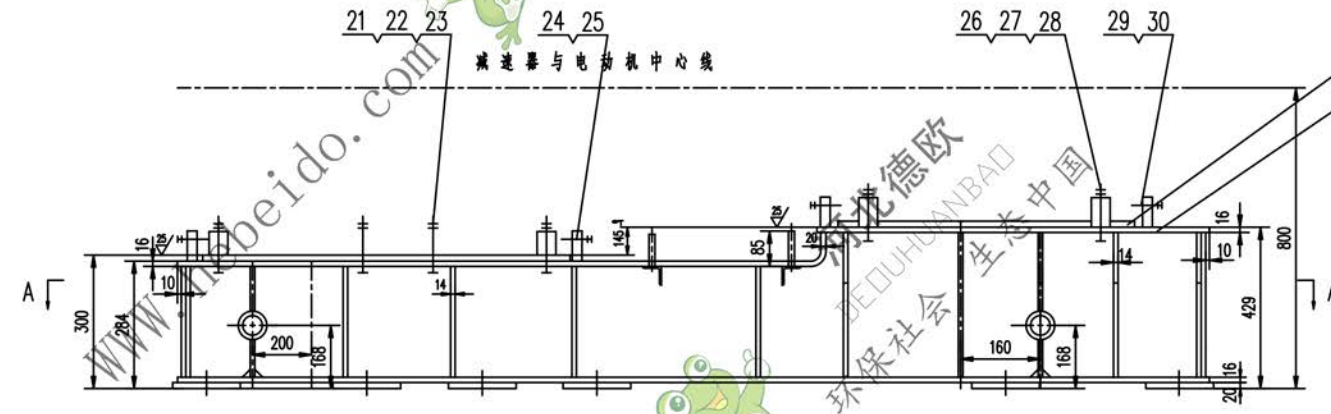

- 技术要求
1. 所有下料表面应做防腐处理
  2. 未注焊缝均为连续角焊, 焊缝高度为被焊件最小厚度
  3. 所有孔表面应做防腐处理
  4. 未注倒角 20X45°
  5. 挡块面做防腐处理
  6. 本图按 GB1059 号图例执行

序号	代号	名称	数量	材料	重量 (kg)	备注
30	GB41-86	螺母	M20	8	—	0.062/0.496
29	GB85-88	螺钉	M20X80	8	—	0.210/1.680
28	GB97.1-85	垫圈	24	4	—	0.032/0.128
27	GB41-86	螺母	M24	8	—	0.112/0.896
26	GB5780-86	螺栓	M24X130	4	—	0.597/2.388
25	GB41-86	螺母	M20	8	—	0.062/0.496
24	GB85-88	螺钉	M20X80	8	—	0.210/1.680
23	GB97.1-85	垫圈	36	8	—	0.092/0.736
22	GB41-86	螺母	M36	16	—	0.371/5.936
21	GB5780-86	螺栓	M36X200	8	—	2.332/18.66
20	—	钢板	φ6	2	Q235-A	145.3/290.7
19	—	钢板	16X120X(280)	16	Q235-A	4.193/67.08
18	—	钢板	14X232X374	5	Q235-A	9.475/47.37
17	—	钢板	14X197X232	10	Q235-A	4.991/49.91
16	—	钢板	(16)X150X1540	2	Q235-A	32.6/65.2
15	—	钢板	16X270X2572	2	Q235-A	88.01/176.0
14	—	角钢	50X50X5-252	4	Q235-A	0.950/3.800
13	—	圆钢	16X85	4	20	0.134/0.536
12	—	管	φ102X12X800	2	Q235-A	21.31/42.62
11	—	钢板	φ14	8	Q235-A	7.596/60.76
10	—	钢板	14X374X377	3	Q235-A	15.39/46.19
9	—	钢板	φ6	2	Q235-A	136.5/273.1
8	—	钢板	20X220X250	14	Q235-A	7.722/108.1
7	—	钢板	φ4	4	Q235-A	1.743/6.972
6	—	钢板	φ4	2	Q235-A	1.054/2.108
5	—	钢板	φ4	2	Q235-A	4.813/9.626
4	—	挡块	φ20	8	Q235-A	0.468/3.744
3	—	挡块	φ20	8	Q235-A	0.390/3.120
2	—	钢板	16X320X1670	2	Q235-A	66.69/133.3
1	—	钢板	(16)X240X1400	2	Q235-A	47.5/95

合图号: J121059

驱动装置架

I. II 型

共 14 页

第 14 页